

2400VS SERIES

Technical Manual



Table of Contents

Introduction	Page 1
Technical Specifications	Page 2
Flow Diagrams	Page 3
Injector & Flow Control Selection	Page 4
Injector	Page 4
Backwash flow control	Page 4
Brine refill flow control	Page 5
Installation	
Assembly	Page 6
Installation	Page 6
Installation check-out	Page 7
Mixing valve	Page 7
Electronic Control Panel	
Programming	Page 10
Diagnostics level	Page 13
Parts Replacement	
Printed Circuit Board	Page 14
Drive motor	Page 15
Injector	Page 15
Backwash flow control	Page 16
Brine refill flow control	Page 16
Brine tee	Page 16
Rotor assembly	Page 16
Seal disk	Page 16
Gasket	Page 17
Float valve	Page 17
Timer head assembly	Page 17
Worm drive shaft	Page 17
Impeller	Page 18
Synchronising valve body and timer head	Page 18
Troubleshooting	Page 20
Annual Maintenance	Page 23
Exploded Views & Part Numbers	
Electronic timer	Page 24
Valve body	Page 26
Order Specifications	Page 28

Art. Nr.: Tech_Man-ENG-2400VS-2013.06

Introduction

The 2400VS is an electronic 4-cycle regeneration control valve for softening of drinking and feed water supplies. The unique motor driven rotor assembly has a minimum of moving parts; together with the 1-piece Noryl® body, this guarantees extremely high flow rates and exceptional reliability. The microprocessor controlled programmer with NOVRAM®, offers unrivalled programming simplicity for use in demand with days override systems. The control valve is designed for hard water bypass during regeneration. A built in adjustable blending device for mixing hard and soft water to suit the particular needs of each installation, is a standard feature. The control valve requires only an aircheck; a conventional float-controlled brine valve system can be used as a double security. The following sequence is followed:

1. SERVICE:

Untreated water flows down through the resin bed and up through the riser tube; the water is conditioned when passing through the resin. The throughput is dependent on the maximum permissible pressure drop for the complete water softener and the maximum permissible specific load of the resin (generally taken as 40 litres soft water per hour per litre resin).

2. BACKWASH:

Water flows down through the riser tube and up through the resin bed to drain; the resin bed is fully expanded and all foreign materials are thoroughly washed from the resin, allowing a good brine cycle to occur.

3. BRINE:

Salt brine, drawn from the brine tank by the injector, slowly flows down through the resin bed and up through the riser tube to drain; the resin is being regenerated when the salt brine passes through. The brine cycle is terminated when the air check is shut.

4. SLOW RINSE:

Slow rinse continues for the remainder of the brine cycle; the injectors motive water slowly flows down through the resin bed and up through the riser tube to drain, slowly washing the brine from the resin tank.

5. FAST RINSE/BRINE REFILL:

Water flows to the brine tank and at the same time down through the resin bed and up through the riser tube to drain, ensuring that all traces of brine are washed out and that the resin bed is compacted. The resin bed is now ready for the next service cycle.

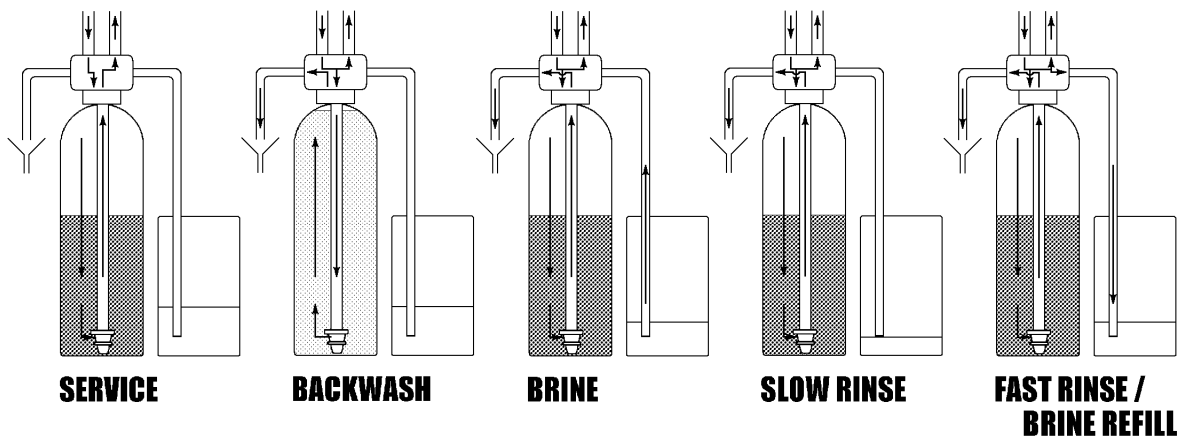

Technical Specifications

<ul style="list-style-type: none"> • Valve body material • Connections <ul style="list-style-type: none"> - inlet/outlet (optional) - drain line - brine line - tank - riser tube • Mixing valve 	<p>Glass filled Noryl®</p> <p>Brass adapters BSP, 3/4" male/female, 1" male 3/4" NPT with hose barb 13 mm Compression fitting 3/8" polytube 2 1/2" - 8 NPSM 1,050" / 26,7 mm Standard</p>
<ul style="list-style-type: none"> • Flow rates (valve with riser) <ul style="list-style-type: none"> - service - backwash - fast rinse 	<p>Kv = 5,5 / Cv = 6,4 Kv = 1,7 / Cv = 2,0 Kv = 1,0 / Cv = 1,2</p>
<ul style="list-style-type: none"> • Application 	<p>Softener 7" - 16"</p>
<ul style="list-style-type: none"> • Operating pressure • Operating temperature • Electrical rating 	<p>1,4 - 8,3 bar / 20 - 120 psi 2 - 48 °C / 35 - 120 °F 24V - 50 Hz, max. 500 mA</p>
<ul style="list-style-type: none"> • Regeneration • Controller <ul style="list-style-type: none"> - software - regeneration initiation - regeneration mode - time of regeneration - days override - water hardness - reserve capacity - backwash - brine draw/slow rinse - fast rinse/brine refill 	<p>4 cycles, co-current brining Electronic with μ-processor and NOV RAM® EAZY Demand with days override or manual Adjustable: delayed, immediate or delayed with immediate override Adjustable Adjustable: OFF, 1 - 30 days Adjustable: 1 - 99 °f, °d Self-calculating or adjustable (0-70% of total cap.) Adjustable: 0 - 20 min Adjustable: 0 - 180 min Adjustable: 0 - 65 min</p>
<ul style="list-style-type: none"> • Flow meter accuracy 	<p>1,4 - 115 L/min: $\pm 10\%$</p>

Flow Diagrams

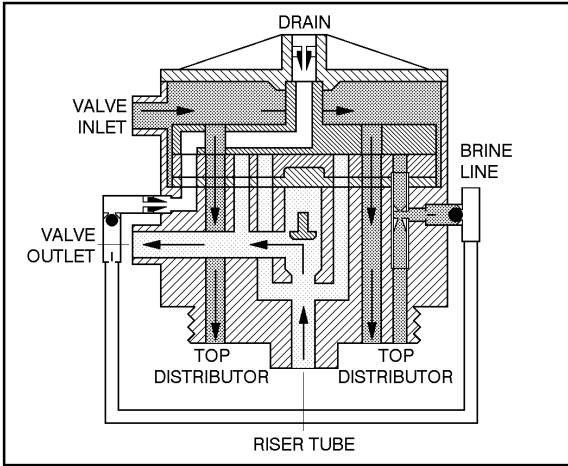

SERVICE

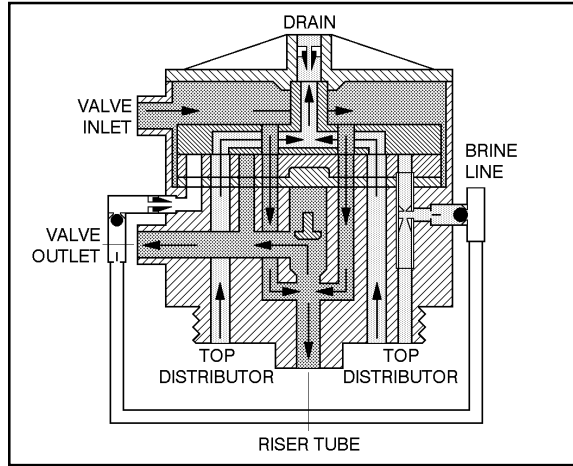

BACKWASH

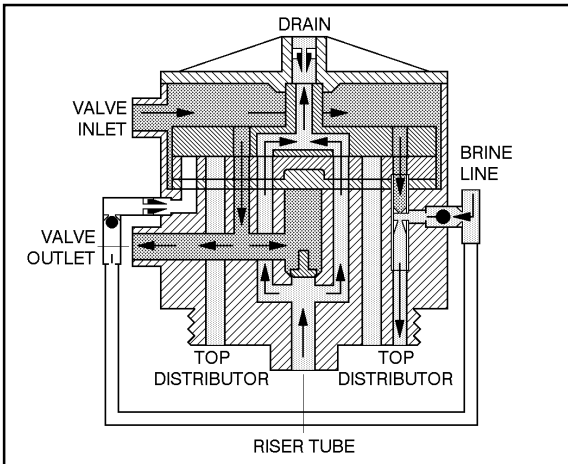

BRINE / SLOW RINSE

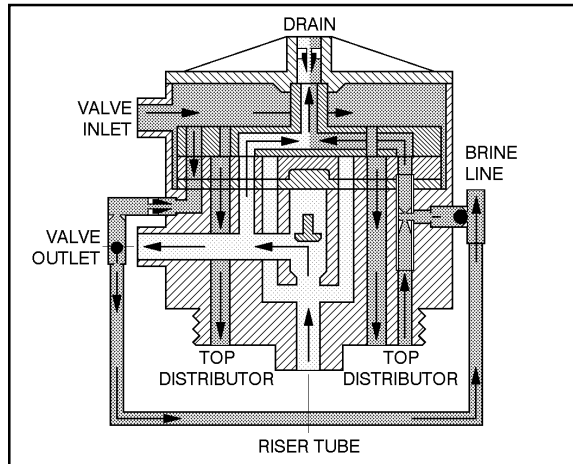

FAST RINSE / BRINE REFILL

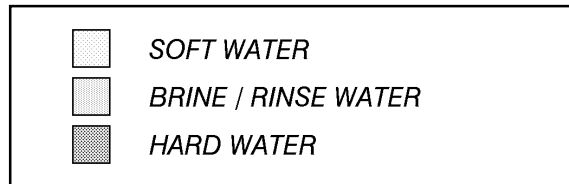

Injector & Flow Control Selection

Injector

The injector determines the brine concentration (ratio between brine suction and rinse water) and the brine flow through the resin bed, thus the contact time between brine and resin. Injector performances vary significantly with inlet pressure.

Press. inlet bar	Inj. 4 (PURPLE)		Inj. 1 (RED)		Inj. 2 (YELLOW)		Inj. 5 (GREEN)	
	Brine L/min	Rinse L/min	Brine L/min	Rinse L/min	Brine L/min	Rinse L/min	Brine L/min	Rinse L/min
1,38	0,64	0,72	1,32	1,21	1,63	1,86	1,14	3,14
2,07	0,64	0,91	1,63	1,40	1,97	2,08	1,48	3,56
2,76	0,64	0,98	1,82	1,51	2,23	2,27	1,70	3,94
3,45	0,68	1,06	2,01	1,63	2,42	2,46	1,97	4,28
4,14	0,68	1,17	2,04	1,78	2,61	2,65	2,20	4,58

!!! The following table is only an indication and is valid for an inlet pressure of 3 bar and a bed height of 30".

Ø Tank		Injector	
inch	mm	Nr.	Colour
7	178	4	PURPLE
8	203	4	PURPLE
9	229	4	PURPLE
10	254	1-4	RED-PURPLE
12	305	1	RED
13	330	1	RED
14	356	2-1	YELLOW-RED
16	406	5-2	GREEN-YELLOW

Backwash flow control

The backwash flow control determines the resin bed expansion during backwash, independent of the inlet pressure. The optimal bed expansion is generally obtained at a backwash flow of 1,8 L/min per dm² of resin bed surface.

Ø Tank		Backwash F.C.	
inch	mm	Nr.	Gal/min (L/min)
7	178	E	1,6 (6,1)
8	203	E	1,6 (6,1)
9	229	G	2,0 (7,6)
10	254	J	2,6 (9,8)
12	305	K	3,5 (13,2)
13	330	L	4,0 (15,1)
14	356	M	5,0 (18,9)
16	406	N	6,0 (22,7)

Brine refill flow control

Together with the time of the fast rinse/brine refill cycle, the brine refill flow control determines the quantity of refill to the brine tank, independent of the inlet pressure:

$$\text{flow control} \times \text{cycle time} = \text{quantity of refill}$$

Do mind that the fast rinse/brine refill cycle can only be set by increments of 1 min!

!!! The following tables are only an indication and are valid for a brine valve with a refill rate that equals or exceeds the rate of the refill flow control.

Nr.	Brine refill F.C.		Program: 3 ^e cycle	Quantity of refill
	Gal/min (L/min)		min	L (±10 %)
A	0,25	(1,0)	4	3,8
A	0,25	(1,0)	6	5,7
A	0,25	(1,0)	8	7,6
A	0,25	(1,0)	10	9,5
B	0,5	(1,9)	6	11,4
B	0,5	(1,9)	8	15,1
B	0,5	(1,9)	10	18,9
D	1,0	(3,8)	6	22,7
D	1,0	(3,8)	8	30,3
D	1,0	(3,8)	10	37,9
D	1,0	(3,8)	12	45,4
/	K _v = 0,27		/	/

∅ Tank		Brine refill F.C.
inch	mm	Nr.
7	178	A-B
8	203	A-B
9	229	B
10	254	B-D
12	305	D
13	330	D
14	356	D
16	406	/

Installation

Assembly

For proper assembly of control valve and resin tank, proceed as follows:

1. Rinse the resin tank well before use.
2. Attach the lower distributor to the riser tube using PVC-glue or a stainless steel pin.
3. Lower the riser tube into the resin tank so that it touches the bottom.
4. Cut the riser tube 13 mm (= 1/2") below the top of the tank threads and chamfer the tube to prepare for insertion into the control valve.
5. Temporary plug the top of the riser tube to prevent resin from entering the tube and fill the tank with resin for max. 3/4 full.
6. Make sure the O-ring in the riser insert of the control valve is in the correct position; screw the upper distributor onto the control valve.
7. Lubricate the threads, the top of the riser tube and the tank O-ring of the control valve.
8. Lower the control valve straight down onto the riser tube and screw it onto the tank.

Installation

!!! ATTENTION

- For proper functioning of the unit, incoming water pressure should be between a minimum of 1,4 bar during regeneration and a maximum of 8,3 bar in service; if necessary, a pressure reducer must be installed ahead of the system.
- Installation must only be undertaken by a person competent in plumbing.
- All plumbing and electrical connections must be done in accordance with local codes.
- Do not install the unit too close to a water heater (min. 3 m of piping between outlet of unit and inlet of heater); water heaters can sometimes transmit heat back down the cold pipe into the control valve; always install a check valve at the outlet of the system.
- If the control valve is not equipped with a bypass, a three valve bypass system must be installed to enable bypassing during servicing.

For proper installation of the unit, proceed as follows:

1. **Inlet/outlet:** connect the inlet and outlet to the control valve; when facing the front of the control valve, the inlet is at the left and the outlet at the right side.
2. **Drain line:** connect a hose to the drain line fitting on the control valve and secure it; insert the drain hose into a standpipe, with siphon if required; make sure the drain hose is:
 - as short as possible,
 - not elevated too much,
 - free of kinks,as this will all create undesired counter-pressure.
3. **Brine line:** an aircheck is required for proper brining during regeneration, but a float-controlled brine valve system can be used as a double security; 3/8" polytube must be used to connect the brine system to the control valve; do not overtighten the nut.
4. **Transformer:** make sure the power source carries the same rating as the transformer; plug transformers output lead (with plug \varnothing 2,5 mm x 5,5 mm) into socket at the timers power lead and plug transformer into socket; the connection can be secured by means of the wire clip.

Installation check-out

When installation has been completed, the unit is ready to be placed into service. Proceed as follows, while checking the unit for any leakages:

1. Place unit in bypass and turn on main water supply; open a cold water tap nearby and allow water to run for a few minutes until all foreign material that may have resulted from the installation is washed out; close the tap.
2. Slowly shift the bypass valve to the service position and secure it; allow water to completely fill the resin tank.
3. Carefully open a cold water tap and allow water to run for at least 2 minutes to set the resin bed and purge air from the unit; close the tap.
4. Program the control valve according to the specific installation (refer to “Programming” on pg. 11).
5. Press the *scroll* Ⓢ button repeatedly until the display shows:

Regen in 10 sec

6. Leave the control valve in this position; the countdown timer will countdown to 0 sec and start a regeneration.
7. The motor will start and the display will show:

Rgn:XXX Cyc1: YY

8. You can press the *scroll* Ⓢ button again to switch the motor to full speed, which will shorten the transfer time needed by the control valve to reach the next position.
9. The motor will move the control valve into backwash position; allow water to run to drain until all of the air is purged from the system.
10. Fill the brine tank with water, higher then the air-check level.
11. Press the *scroll* Ⓢ button; the motor will start and the display will show:

Rgn:XXX Cyc2:YYY

12. The motor will move the control valve into brine/slow rinse position; allow it to draw water from the brine tank until the aircheck closes.
13. Press the *scroll* Ⓢ button; the motor will start and the display will show:

Rgn:XXX Cyc3: YY

14. The motor will move the control valve into fast rinse/brine refill position; allow water to run to drain and brine tank for the entire cycle time, to fill the brine tank to the programmed level.
15. Add salt to the brine tank.

Mixing valve

To adjust the residual hardness, the incorporated mixing valve must be regulated in function of the hardness of the incoming water and the desired residual hardness

- To increase the residual hardness: turn screw counter clockwise.
- To decrease the residual hardness: turn screw clockwise.

Electronic Control Panel

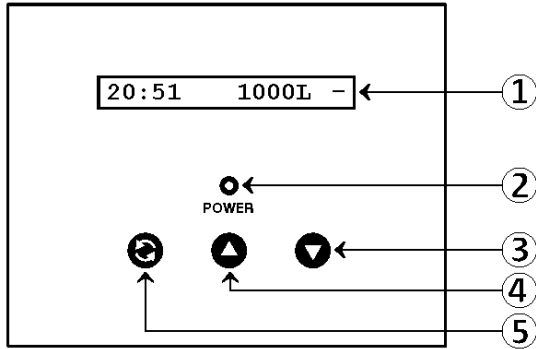

- ① display
- ② **POWER led:** lights up when electrical power is applied
- ③ **DOWN button:** to decrease the value of the parameter
- ④ **UP button:** to increase the value of the parameter
- ⑤ **SCROLL button:** to advance to the next parameter

Power-up

After power-up, the display will show the installed software version for 5 seconds, f.e.:

EZRSDg EZ Rot0.8

Afterwards it will automatically revert back to the service display.

The POWER led will light up.

Power failure

In the event of a power failure, the program will remain stored in the NOVRAM® during an undefined period, while an incorporated SuperCap (capacitor) will maintain the correct time of day during a period of several hours; consequently, in case of prolonged power failure, the time of day might not be maintained; if this happens, the time of day indication will *flash* when the power supply is re-established, indicating that the time of day needs to be set.

When the power failure occurs during the execution of an automatic regeneration, the control valve will remain in its last position; when the power supply is re-established, the control valve will return to the service position, stay there for 60 sec. and restart a complete regeneration from the beginning.

Timer failure

In the event of a timer failure, the display will show the message:

Service Required

In such case, entering one of the programming levels can possibly solve the problem. However if the problem persists, professional service is required.

Service mode

In **service mode** the display shows the time of day, the remaining capacity and the water usage indicator:

20:51 1000L -

Every day the control valve automatically recalculates the reserve capacity, as a progressing average. Permanently it compares the remaining capacity with the calculated reserve capacity; as soon as the remaining capacity equals the calculated reserve capacity, the display will show the time of day and the indication "REGEN", indicating that a delayed regeneration will be started at the pre-programmed time of regeneration:

20:51 REGEN-

In case the resin bed is fully exhausted (remaining capacity equals zero) before a delayed regeneration can take place, the unit will regenerate immediately.

Regeneration mode

In **regeneration mode** the display shows the total remaining regeneration time, the actual regeneration cycle and the remaining cycle time:

Rgn: 67 Cyc2: 45

total remaining regen. time actual regen. cycle remaining cycle time

The control valve can be **reset to service mode** at any time by pressing the *scroll* ⏪ button, as such manually advancing it through the regeneration cycles.

Checking the flow meter

In case of water usage, the remaining capacity counter in the service display will count back per unit, i.e. per litre; furthermore the water usage indicator will revolve. This way the correct functioning of the water meter can be verified.

Manual regeneration

It is possible to manually initiate a regeneration.

1. Press the *scroll* ⏪ button repeatedly until the display shows:

Regen in 10 sec

- If the control valve is left in this position, the countdown timer will countdown to 0 sec and *start a regeneration*.
- To cancel this mode, press the *scroll* ⏪ button before the countdown timer has reached 0 sec; the control valve will return to the service mode.

Programming

- During programming, it is necessary to enter the desired change within 60 sec. Otherwise the microprocessor will automatically break off the programming and return to the service mode, *while all possibly entered changes to the program are lost*. If this occurs, it will be necessary to re-initiate the programming process.
- All programming parameters are grouped into different user-specific levels (End-User / Parameter Set / Diagnostics). The end-user level is accessible freely; in order to access one of the other specific levels, the proper access code, i.e. key sequence, needs to be entered.
- In the programming modes, a *flashing* indication implicates that this parameter can be adjusted by pressing the *up* ▲ button or *down* ▼ button; in this technical manual this is indicated by means of an *italic* font.

Programming instructions - End-User level

Before entering the programming mode, make sure that the control valve is in the service mode.

1. Press the *scroll* ⌂ button; the display will show:

Language: *English*

- Press the *up* ▲ button or *down* ▼ button to set *the language*.

2. Press the *scroll* ⌂ button again; the display will show:

Set time: *20:51*

- Press the *up* ▲ button or *down* ▼ button to set *the time of day*.

3. Press the *scroll* ⌂ button again; the display will show:

Set hardn.: *XX°f*

- Press the *up* ▲ button or *down* ▼ button to set *the water hardness of the incoming untreated water*.

Programming instructions - Parameter Set level

In the Parameter Set level the basic configuration parameters of the unit can be programmed, depending on the specific configuration of the unit.

Before entering the programming mode, make sure that the control valve is in the service mode.

1. Press the **scroll**  button and hold it for 5 sec until the display shows:

System Check



2. Within 10 sec, press the **up**  button; the display will show:

HardUnit: °f

- Press the **up**  button or **down**  button to set *the units of hardness*.

3. Press the **scroll**  button again; the display will show:

ExCap: 5.2°f M3/L

- Press the **up**  button or **down**  button to set *the exchange capacity per litre of resin*.



4. Press the **scroll**  button again; the display will show:

Resin: 20 liters

- Press the **up**  button or **down**  button to set *the volume of resin*.

5. Press the **scroll**  button again; the display will show:

Override: 4 days

- Press the **up**  button or **down**  button to set *the number of days between regenerations*.

6. Press the **scroll**  button again; the display will show:



Cycle 1: 5 min

- Press the **up**  button or **down**  button to set *the length of the regeneration cycle*.

		Default setting	Setting range
Cycle 1	Backwash	5 min	0-20 min
Cycle 2	Brine draw/slow rinse	60 min	0-180 min
Cycle 3	Fast rinse/refill	5 min	0-65 min



7. Press the **scroll**  button again; the display will show:

MTR: SNAP SENSOR

- Press the **up**  button or **down**  button to set *the model of flow meter used*:
 - **SNAP SENSOR**: model with snap-on flow meter sensor.
 - **SCREW SENSOR**: model with sensor fixed by means of screw.

8. Press the **scroll**  button again; the display will show:

Regen:Dlyd/Immd

- Press the **up**  button or **down**  button to set *the regeneration mode*:
 - **Dlyd/Immd**: when the remaining capacity equals the reserve capacity, a *delayed regeneration* is started at the programmed time of regeneration; however when the remaining capacity equals 0 before the programmed time of regeneration is reached, an *immediate regeneration* is started.
 - **Immediate**: when the remaining capacity equals 0, an *immediate regeneration* is started.
 - **Delayed**: when the remaining capacity equals the reserve capacity, a *delayed regeneration* is started.





9. Press the **scroll**  button again; the display will show (only when the regeneration mode was set to 'Delayed' or 'Dlyd/Immd'):

Regen @ 2:00

- Press the **up**  button or **down**  button to *set the time of regeneration*.



10. Press the **scroll**  button again; the display will show (only when the regeneration mode was set to 'Delayed' or 'Dlyd/Immd'):

Rsrv Variable

- Press the **up**  button or **down**  button to set *the reserve capacity*:
 - **Variable**: the reserve capacity is calculated automatically, based on the registered daily water usage.
 - **Fxd**: press the **scroll**  button again and press the **up**  button or **down**  button to set *the reserve capacity to a fixed amount*.

11. Press the **scroll**  button again; the display will show:

Exit

- Press the **up**  button or **down**  button to save the program to the NOVRAM® and exit the programming level.

Diagnostics level

Besides of all programming parameters, a series of operating parameters can be consulted in the diagnostics level; particularly during a service intervention, these parameters can be helpful to identify the cause of a problem.

1. Accessing the Diagnostics level:

- Make sure that the control valve is in the service mode.
- Press the **scroll** ⤴ button and hold it for 5 sec until the display shows:

System Check

- Within 10 sec, press the **down** ▼ button; the display will show:

Regen XXdays ago

- You are now in the Diagnostics level; use the **scroll** ⤴ button to advance through the different diagnostics parameters.

2. Exiting the Diagnostics level:

- If no button is pressed within a time frame of 5 minutes, the microprocessor will exit the diagnostics level and return to the service mode.
- Press the **scroll** ⤴ button until the display shows:

Exit

- Press the **up** ▲ button or **down** ▼ button to exit the Diagnostics level.

3. Available diagnostic parameters:

- **Regen X days ago**: display shows number of days since last regeneration of the unit.
- **In Srvc**: displays show how many days the unit has been in service.
- **# of Regens**: display shows the number of regenerations that have taken place since installation.
- **TotVol**: display shows the total water usage through the unit since installation.
- **LastRgn@**: display shows the water usage at the moment of the last regeneration.
- **InstFlow**: display shows the instantaneous flow rate.
- **AvgVol**: display shows the average daily water usage.
- **Capacity**: display shows the calculated volume of softened water between regenerations.
- **Hardness**: display shows the setting of the water hardness.
- **Rsrv**: display shows the setting of the reserve capacity.
- **Regen @**: display shows the setting of the time of regeneration.
- **Override**: display shows the setting of the number of days between regenerations.
- **Cycle X**: display shows the setting of the length of the corresponding regeneration cycle.
- **Units**: display shows that control is programmed for Metric units.
- **MTR**: display shows the setting of the water meter.
- **Capacity**: display shows that control is programmed for hardness setting.
- **Regen**: display shows the setting of the regeneration mode.
- **Valve Type**: display shows the valve type setting.
- **MP Resets**: display shows the number of resets of the microprocessor (*for factory purpose only*).
- **Memory Reset**: display shows the number of corrupt memory start-ups (*for factory purpose only*).
- **EZ**: display shows the software version (*for factory purpose only*).
- **CapToUse**: display shows the remaining capacity.

Parts Replacement

!!! BEFORE SERVICING:

- MAKE SURE THE CONTROL VALVE IS IN SERVICE POSITION
- DISCONNECT ALL ELECTRICAL POWER TO THE UNIT
- BYPASS OR DISCONNECT THE WATER SUPPLY
- RELIEF THE WATER PRESSURE

Printed Circuit Board

1. Loosen the 3 front cover screws and remove the front cover.
2. Disconnect all connectors from the PCB.
3. Remove the flat cable of the 3-button control pad from the push-in connection on the PCB.
4. Remove the screws holding the PCB in place.
5. Push aside the clip holding the PCB in place and remove the PCB.
6. Reverse the procedure for reassembly; refer to wiring diagram for proper lead connections.

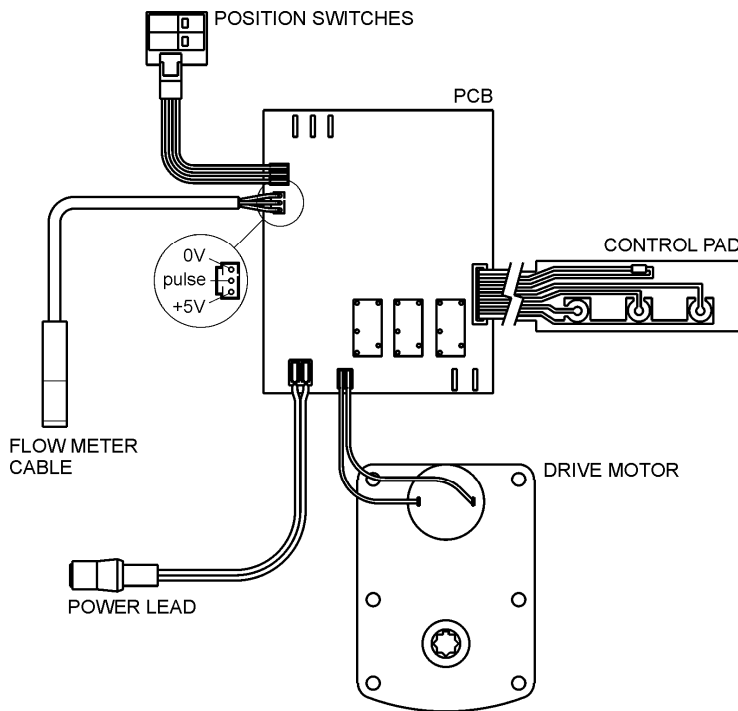

Drive motor

1. Remove the timer head assembly; refer to Parts Replacement “Timer head assembly”.
2. Loosen the 3 front cover screws and remove the front cover.
3. Disconnect the wire connector from the drive motor.
4. At the back of the back plate, remove the 2 screws holding the drive motor assembly in place and remove the micro switch assembly and drive motor.
5. Remove the retaining ring securing the worm and remove the worm from the drive shaft.
6. Pull the drive shaft out of the drive motor.
7. Install the drive shaft in the drive motor, with the flat side on the drive shaft pointing down (mark on the drive shaft pointing up (1)).
8. Install the worm on the drive shaft and install the retaining ring securing the worm.
9. Put the micro switch assembly on the drive motor; make sure the switch cam is in the service position (2).
10. Install the micro switch assembly and drive motor on the back plate and secure it with the 2 screws.
11. Connect the wire connector on the drive motor; refer to wiring diagram for proper connection.
12. It is now necessary to check the synchronisation of valve body and timer head; refer to to Parts Replacement “Synchronising valve body and timer head”.

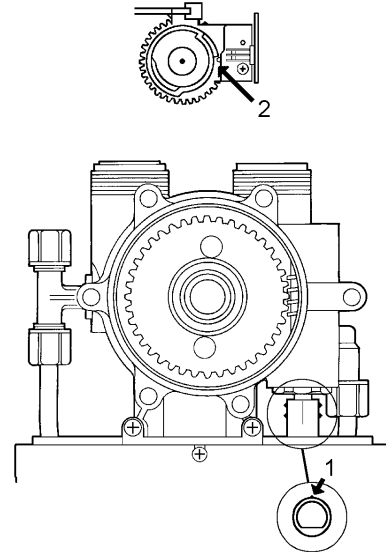

Injector

1. Remove the drain hose from the drain elbow.
2. Remove the 6 bolts holding the valve body and cover together.
3. Lift the valve cover away from the valve body.
4. Remove the rotor assembly from the valve cover; the white Teflon O-ring will remain in the valve cover.
5. Remove the seal plate from the valve body.
6. Remove the insert plate and gasket from the valve body.
7. Using a needle nose pliers grasp one side of the injector and pull the injector straight out of the valve body.
8. Make sure the float valve is straight up into the float chamber of the valve body.
9. Install the insert plate and gasket in the valve body.
10. Lightly lubricate the O-rings of the new injector with a soap water solution.
11. Install the injector with one of the rectangular openings on the injector facing directly towards the centre of the valve body; push the injector firmly down.
12. Install the seal disk in the valve body, with the green side facing up.
13. Install the rotor assembly into the valve body ensuring that the arrow on the worm gear is pointing directly towards the second tooth on the worm drive shaft (facing the front of the control valve); the 2 holes in the rotor assembly should now be exactly aligned with the corresponding holes in the seal disk.
14. Centre the PVC sleeve on the worm gear.
15. Make sure the valve cover O-ring is clean and securely installed around the raised rib on the valve cover.
16. Lower the valve cover straight down onto the valve body and press it down firmly and evenly to seat the valve cover.
17. Install the 6 bolts and tighten them in a cross pattern.
18. Install the drain hose to the drain line fitting.

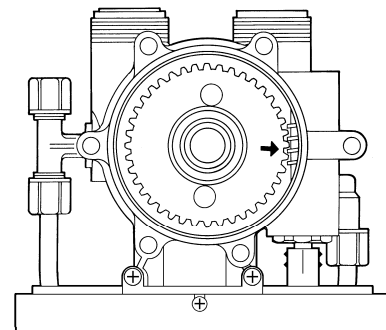
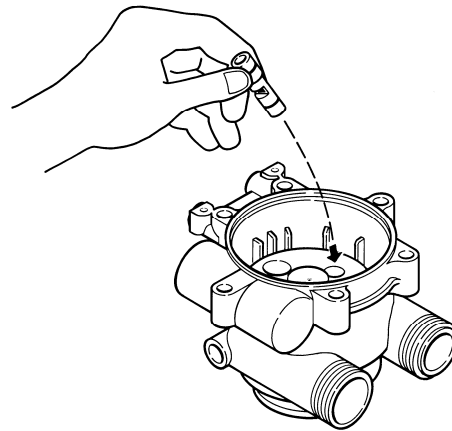

Backwash flow control

1. Remove the drain hose from the drain elbow and remove the drain elbow.
2. Unscrew the backwash flow control using a 3/8" Allen wrench.
3. Reverse the procedure for reassembly.

Brine refill flow control

1. Remove the clip securing the refill elbow.
2. Remove the brine refill flow control from the refill elbow.
3. Reverse the procedure for reassembly.

Brine tee

1. Remove the brine line and brine refill tube from the brine tee.
2. Remove the brine tee by turning it counter clockwise.
3. Remove the O-ring, the retainer and check ball from the brine tee.
4. Reverse the procedure for reassembly.

Rotor assembly

1. Remove the drain hose from the drain elbow.
2. Remove the 6 bolts holding the valve body and cover together.
3. Lift the valve cover away from the valve body.
4. Remove the rotor assembly from the valve cover; the white Teflon O-ring will remain in the valve cover.
5. Inspect the rotor plate's surface; it should be smooth and free of any circular grooves or scratches; replace if necessary.
6. Install the rotor assembly into the valve body ensuring that the arrow on the worm gear is pointing directly towards the second tooth on the worm drive shaft (facing the front of the control valve); the 2 holes in the rotor assembly should now be exactly aligned with the corresponding holes in the seal disk.
7. Centre the PVC sleeve on the worm gear.
8. Make sure the valve cover O-ring is clean and securely installed around the raised rib on the valve cover.
9. Lower the valve cover straight down onto the valve body and press it down firmly and evenly to seat the valve cover.
10. Install the 6 bolts and tighten them in a cross pattern.
11. Install the drain hose to the drain line fitting.

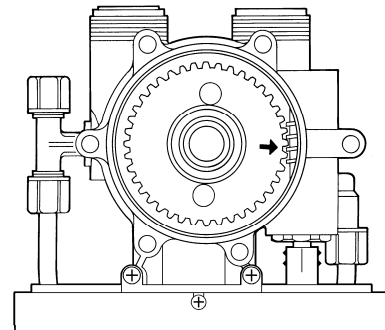

Seal disk

1. Remove the rotor assembly; refer to Parts Replacement "Rotor assembly".
2. Remove the seal disk from the valve body.
3. Inspect the seal disk; make sure the raised ribs are intact; the green Teflon coating may be worn off of the ribs, but this won't affect the sealing performance of the seal disk; replace if necessary.
4. Use silicone base lubricant to lubricate the green side of the seal disk.
5. Install the seal disk in the valve body, with the green side facing up.
6. Reverse the procedure for reassembly; refer to Parts Replacement "Rotor Assembly".

Gasket

1. Remove the seal disk; refer to Parts Replacement “Seal disk”.
2. Remove the insert plate and gasket from the valve body
3. Inspect the insert plate; make sure the ribs are intact.
4. Using a needle nose pliers grasp one side of the injector and pull the injector straight out of the valve body.
5. Clean the surface of the valve body.
6. Make sure the float valve is straight up into the float chamber of the valve body.
7. Install the insert plate and gasket in the valve body.
8. Install the injector with one of the rectangular openings on the injector facing directly towards the centre of the valve body; push the injector firmly down.
9. Reverse the procedure for reassembly; refer to Parts Replacement “Seal disk”.

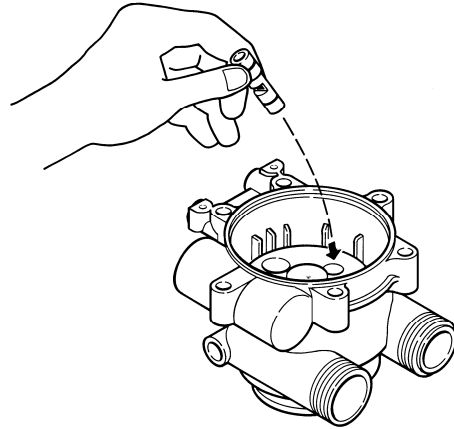

Float valve

1. Remove the gasket; refer to Parts Replacement “Gasket”.
2. Remove the float valve straight out of the float valve chamber of the valve body.
3. Remove the spring from the float valves shaft.
4. Clean all sealing surfaces inside of the float chamber.
5. Install the spring inside of the float valves shaft.
6. Install the float valve straight up into the float chamber of the valve body.
7. Reverse the procedure for reassembly; refer to Parts Replacement “Gasket”.

Timer head assembly

1. Remove the screw holding the flow meter sensor in place and remove the flow meter sensor.
2. Remove the 2 back plate mount screws and take away the timer head assembly.
3. Reverse the procedure for reassembly.

Worm drive shaft

1. Remove the timer head assembly; refer to Parts Replacement “Timer head assembly”.
2. Unscrew the packing gland nut.
3. Remove the packing gland nut/worm drive shaft from the valve body.
4. Separate the packing gland nut from the worm drive shaft.
5. Inspect the worm drive shaft; the threads should not be deformed or damaged; replace if necessary.
6. Install the worm drive shaft in the valve body, by turning it clockwise as far as possible.
7. Lubricate the O-rings of the worm drive shaft.
8. Install the packing gland nut over the worm drive shaft and screw it into the valve body.
9. Install the timer head assembly to the valve body and tighten the 2 back plate mount screws.
10. It is now necessary to check the synchronisation of valve body and timer; refer to Parts Replacement “Synchronising valve body and timer head”.

Impeller

1. Remove the outlet from the control valve.
2. Remove the hub holding the impeller in place.
3. Remove the impeller.
4. Reverse the procedure for reassembly.

Synchronising valve body and timer head

To insure the proper operation of the control valve, valve body and timer head should be synchronised in the service position. Proceed as follows:

Step 1: Timer head

1. Make sure that the control valve is in the service mode; if the control valve is in regeneration, press the *scroll*  button, thus manually advancing it through the regeneration cycles, until the display shows the time of day:

20:51	1000L
-------	-------

2. The flat side on the drive shaft should be pointing down (mark on the drive shaft pointing up (1)); if this is not the case: refer to Parts Replacement “Drive motor”.

Step 2: Valve body

1. Remove the drain hose from the drain elbow.
2. Remove the 6 bolts holding the valve body and cover together.
3. Lift the valve cover away from the valve body.
4. Make sure the arrow on the worm gear is pointing directly towards the second tooth on the worm drive shaft (facing the front of the control valve) (2); the 2 holes in the rotor assembly should now be exactly aligned with the corresponding holes in the seal disk.
5. Make sure the valve cover O-ring is clean and securely installed around the raised rib on the valve cover.
6. Lower the valve cover straight down onto the valve body and press it down firmly and evenly to seat the valve cover.
7. Install the 6 bolts and tighten them in a cross pattern.
8. Install the drain hose to the drain line fitting.

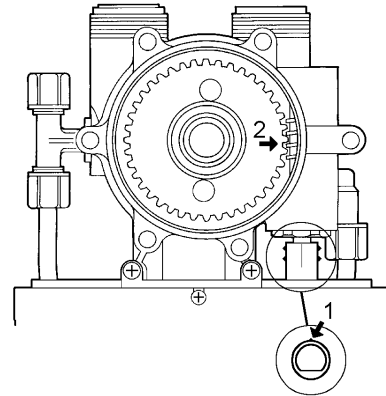

Troubleshooting

Hard (untreated) water to service

Cause	Solution
1. Open or defective bypass	1. Close or verify bypass
2. Control valve in regeneration	2. /
3. Leak between rotor and seal disk	3. Verify or replace rotor and seal disk
4. Loss of resin	4. Refer to problem "Loss of resin"
5. Mixing valve open	5. Reduce mixing valve opening
6. Change in raw water hardness	6. Adjust programming accordingly
7. Valve body and timer out of synchronisation	7. Synchronise valve body and timer
8. Unit fails to regenerate	8. Refer to problem "Unit fails to regenerate"
9. Control valve fails to draw brine	9. Refer to problem "Control valve fails to draw brine"
10. Decreasing exchange capacity of resin	10. Clean or replace resin bed
11. No salt in brine tank	11. Add salt
12. Leak at riser tube	12. Verify that riser tube is seated correctly and is not cracked

Unit fails to regenerate

Cause	Solution
1. Faulty electrical supply	1. Verify electrical service (fuse, transfo,...)
2. Defective flow meter	2. Clean and/or replace flow meter
3. Defective PCB	3. Replace PCB
4. Defective drive motor	4. Replace drive motor
5. Defective micro switch	5. Replace micro switches

Control valve fails to draw brine

Cause	Solution
1. Low inlet pressure	1. Verify operating pressure; must exceed 1,4 bar
2. Plugged injector	2. Clean injector
3. Restricted drain line	3. Verify drain line for kinks, verify backwash flow control to insure it is free of debris
4. Restricted brine line	4. Verify brine line for kinks or restrictions
5. Leak in brine line	5. Verify brine line and connections for air leakage
6. Not enough water in brine tank	6. Refer to problem "Control valve fails to refill brine tank"

Control valve cycles continuously

Cause	Solution
1. Defective or shorted micro switch	1. Replace micro switches

Excessive water in brine tank

Cause	Solution
1. Control valve fails to draw brine	1. Refer to problem “Control valve fails to draw brine”
2. Improper fast rinse/brine refill time setting	2. Verify that fast rinse/brine refill time corresponds to the proper salt level and amount of resin
3. Improper or missing brine refill flow control	3. Verify that flow control is installed and properly sized
4. Leak between rotor and seal disk	4. Verify or replace rotor and seal disk

Control valve fails to refill brine tank

Cause	Solution
1. Improper fast rinse/brine refill time setting	1. Verify that fast rinse/brine refill time corresponds to salt level and amount of resin
2. Improper refill flow control	2. Verify that flow control is properly sized
3. Plugged refill flow control	3. Verify that flow control is free of debris

Unit uses too much salt

Cause	Solution
1. Excessive water in brine tank	1. Refer to problem “Excessive water in brine tank”
2. Unit regenerates too frequently	2. Verify program

Salt water to service

Cause	Solution
1. Excessive water in brine tank	1. Refer to problem “Excessive water in brine tank”
2. Injector undersized	2. Verify injector selection
3. Improper brine/slow rinse time setting	3. Verify that brine/slow rinse time corresponds to the proper salt level and amount of resin
4. Improper fast rinse/brine refill time setting	4. Verify that fast rinse time corresponds to the proper salt level and amount of resin

Loss of resin through drain line

Cause	Solution
1. Improper or missing backwash flow control	1. Verify that flow control is installed and correctly sized
2. Lower and/or upper distributor damaged	2. Replace distributor(s)
3. Leak between riser tube and upper distributor	3. Verify that riser tube is seated correctly and is not cracked

Loss of water pressure

Cause	Solution
1. Mineral or iron build-up in resin tank	1. Clean resin bed and control valve; increase regeneration frequency
2. Plugged lower and/or upper distributor	2. Verify that distributors are free of debris
3. Crushed lower and/or upper distributor	3. Replace distributor(s)

Drain flows continuously

Cause	Solution
1. Defective PCB	1. Replace PCB
2. Defective micro switch	2. Replace micro switches
3. Defective drive motor	3. Replace drive motor
4. Valve body and timer out of synchronisation	4. Synchronise valve body and timer
5. Leak between rotor and seal disk	5. Verify or replace rotor and seal disk

Annual Maintenance

To assure the correct functioning of the control valve, the following items must be checked annually:

1. Clean out injector.
2. Clean brine refill flow control.
3. Clean backwash flow control.
4. Verify correct functioning of flow meter; clean impeller if necessary.
5. Verify programming of timer; re-program timer if necessary.
6. Measure the residual hardness; adjust mixing valve if necessary.
7. Verify min and max. pressure; install pressure reducer if necessary.

Exploded Views & Part Numbers

Electronic timer

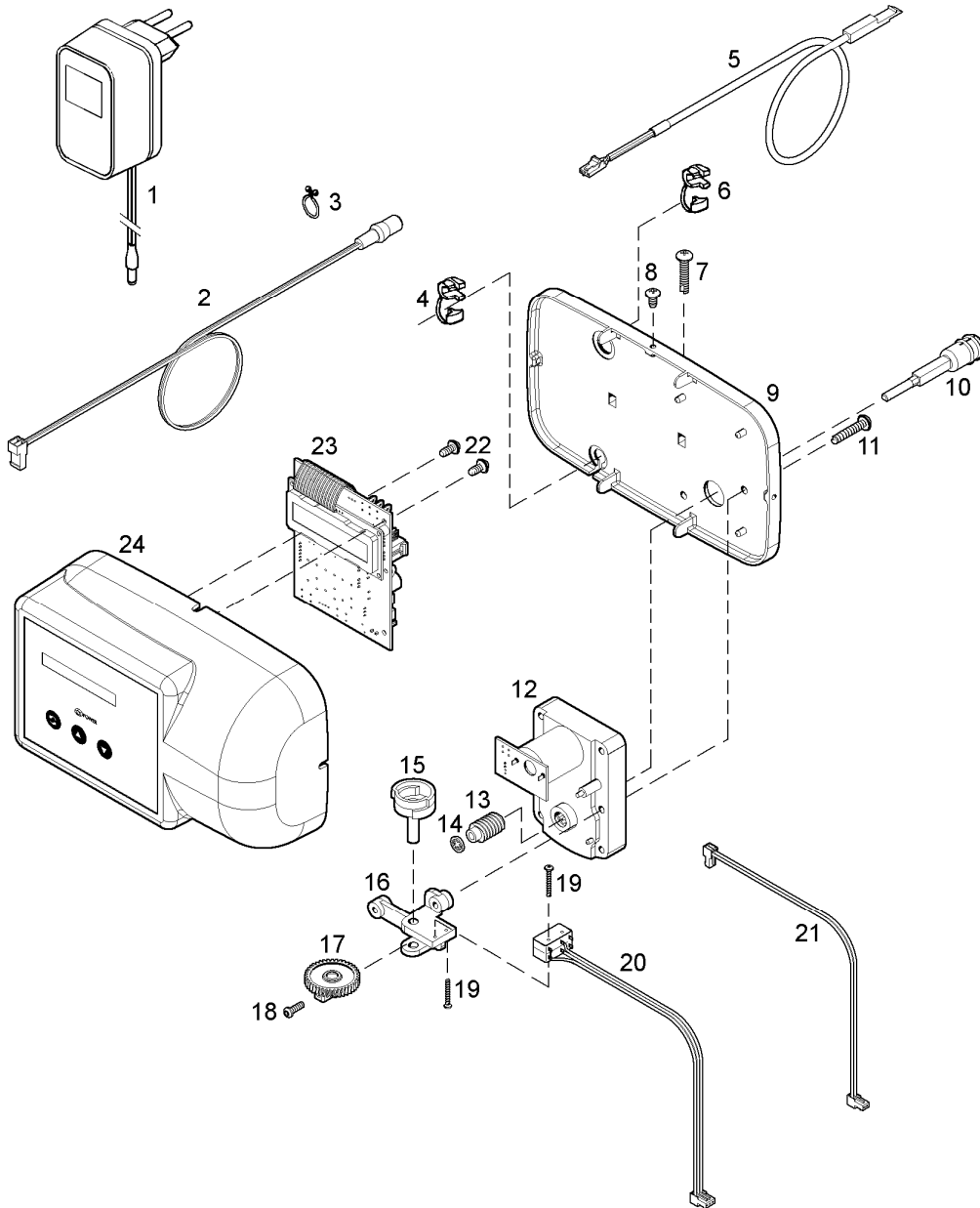

2400VS SERIES

ITEM	PART NUMBER	DESCRIPTION
1	28/297/11	Transfo 230/24V - 50 Hz, 12VA, EuroT plug
	28/297/18	Transfo 230/24V - 50 Hz, 12VA, UK plug
2	70971	Power lead with plug
3	72263	Wire clip
4	70312	Strain relief, power lead
5	72519	Flow meter cable
6	28/8/7	Strain relief, flow meter cable
7	15/222	Screw, back plate (2x)
8	71502	Screw, timer cover (3x)
9	70962	Back plate
10	2100/206	Drive shaft
11	15/222	Screw, drive motor assy (2x)
12	72261	Drive motor
13	568/227/2	Worm
14	19/48	Retaining ring
15	70965	Switch cam
16	568/386	Bracket, micro switches
17	568/310	Gear, switch cam
18	15/184/7	Locking screw, switch cam
19	15/173/12	Screw, micro switches (2x)
20	72451	Micro switch assy
21	71679	Cable set, drive motor
22	15/102	Screw, PCB (2x)
23	72627	Printed Circuit Board
24	72614	Timer cover

Valve body

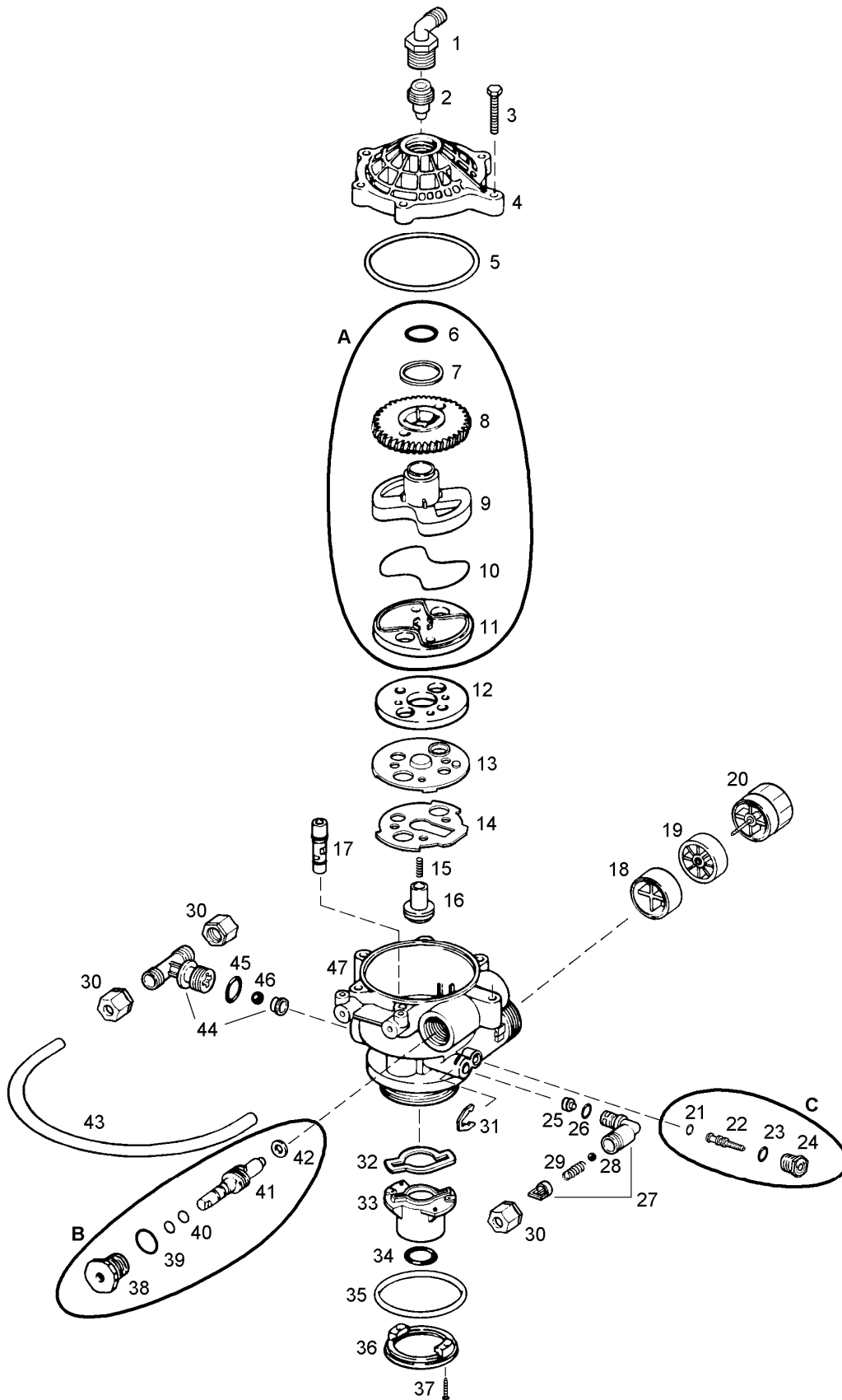

2400VS SERIES

ITEM	PART NUMBER	DESCRIPTION
1	21/83	Drain connection
2	568/271/*	Backwash flow control
3	72678	Bolt, valve cover (6x)
4	568/254/3	Valve cover
5	185/154/1	O-ring, valve cover
6	186/112	O-ring, Teflon
7	72327	Washer, PE
8	568/260	Worm gear
9	568/259	Rotor cam
10	185/041/1	O-ring, rotor
11	568/345/2	Rotor plate
12	568/256	Seal disk
13	568/383	Insert plate
14	568/384	Gasket
15	413/62	Spring, float valve
16	568/270/4	Float valve
17	568/274/*	Injector
18	72458	Diffuser, impeller
19	72544	Impeller
20	72545	Hub, impeller
21	185/007/6	O-ring, mixing valve
22	568/406	Mixing valve
23	186/118	O-ring, sleeve
24	568/407/L	Sleeve, mixing valve
25	568/385/2/*	Brine refill flow control
26	186/118	O-ring, refill elbow
27	568/336	Refill elbow
28	541/275	Check ball, refill elbow
29	413/62	Spring, refill elbow
30	21/88	Nut, refill elbow/brine tee (3x)
31	541/254	Spring clip
32	570/251	Gasket, riser
33	568/334	Riser insert 1,050"
34	185/214/1	O-ring, riser tube
35	185/337/1	O-ring, tank
36	541/232	Adapter ring
37	15/207/12	Screw, adapter ring (2x)
38	72772	Packing gland nut (plastic)
39	185/211/1	O-ring, packing gland nut
40	186/115	O-ring, worm drive shaft (2x)
41	568/208/2	Worm drive shaft
42	14/43	Washer, worm drive shaft
43	EB64/33	Brine refill tube
44	568/340	Brine tee
45	185/208/1	O-ring, brine tee
46	26/47/12N	Check ball, brine tee
47	72801	Valve body
A	RK/568/259/2	Repair kit rotor
B	RK/75154	Repair kit packing gland nut
C	RK/568/406	Repair kit mixing valve

* Size: refer to "Sizing Table"

Order Specifications

2400VS/VIBR

V = Voltage: **L** = transfo 230/24VAC, 12VA, EuroT plug
 R = transfo 230/24VAC, 12VA, UK plug
 J = no transfo

I = Injector: **4, 1, 2, 5**

B = Backwash flow control:

0 = no flow control

Nr.	Gal/min	(L/min)
E	1,6	(6,1)
F	1,8	(6,8)
G	2,0	(7,6)
H	2,2	(8,3)
J	2,6	(9,8)
T	3,0	(11,4)
K	3,5	(13,2)
L	4,0	(15,1)
M	5,0	(18,9)
N	6,0	(22,7)
P	7,0	(26,5)
Q	8,0	(30,3)
R	9,0	(34,1)
S	10,0	(37,9)

R = Refill flow control:

0 = no flow control

Nr.	Gal/min	(L/min)
A	0,25	(1,0)
B	0,5	(1,9)
D	1,0	(3,8)

